







ASSEMBLY INSTRUCTION

DESCRIPTION : DRESSER / MIRROR

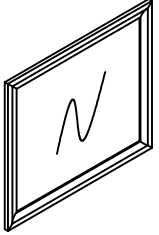
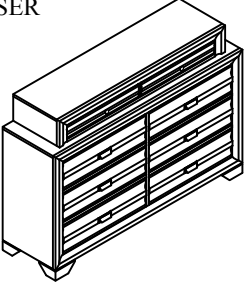
MODEL :

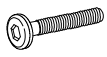
C5236A-040-8DXX / C5236A-050-MHXX
 C5236W-040-8DXX / C5236W-050-MHXX
 C5236W-047-8DXX / C5236W-050-MHXX
 C5236G-040 / C5236G-050

REVISION : B

NO	PARTS & HARDWARE	QTY.
A	MIRROR 	1PC
B	DRESSER 	1PC
C	MIRROR SUPPORT 	2PCS
D	JCBC M6 x 35mm 	8PCS
E	SPRING WASHER 1/4"mm 	8PCS
F	FLAT WASHER 1/4" x 20mm 	8PCS
G	L KEY M4 	1PC

STEP 1 : ATTACH MIRROR SUPPORT (C) TO THE MIRROR BACK (A)
 AS STEP 1, THEN TIGHTEN WITH JCBC (D), SPRING WASHER (E)
 & FLAT WASHER (F) BY USING L KEY (G).
 MAKE SURE MARKING LINE OF SUPPORT MUST SAME LEVEL
 AS BOTTOM OF MIRROR BASE.

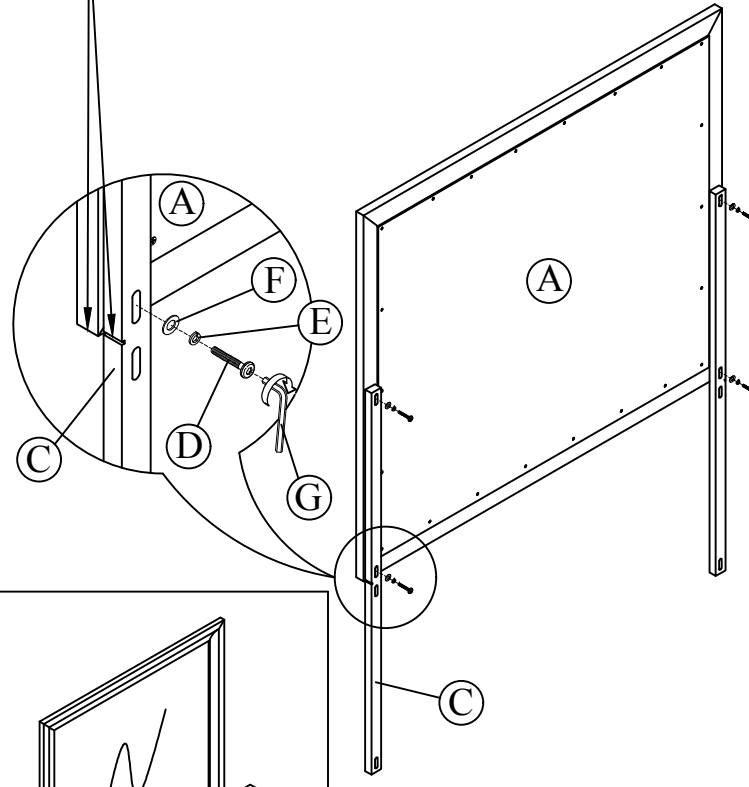

STEP 2 : PLACE THE MIRROR WITH SUPPORT ON
 TOP OF DRESSER (B). THEN ALIGN CENTER.
 AS SHOWN AND TIGHTEN WITH JCBC (D), SPRING
 WASHER (E) & FLAT WASHER (F) BY USING
 L KEY (G).

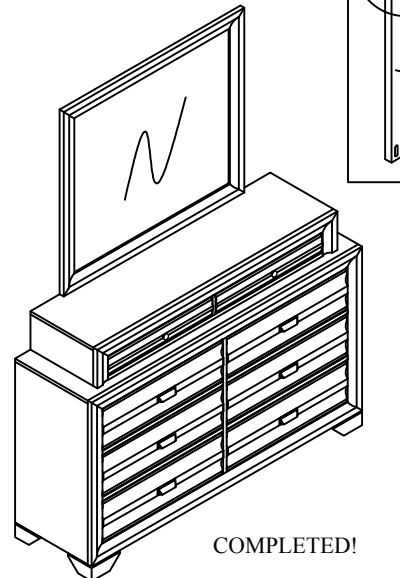
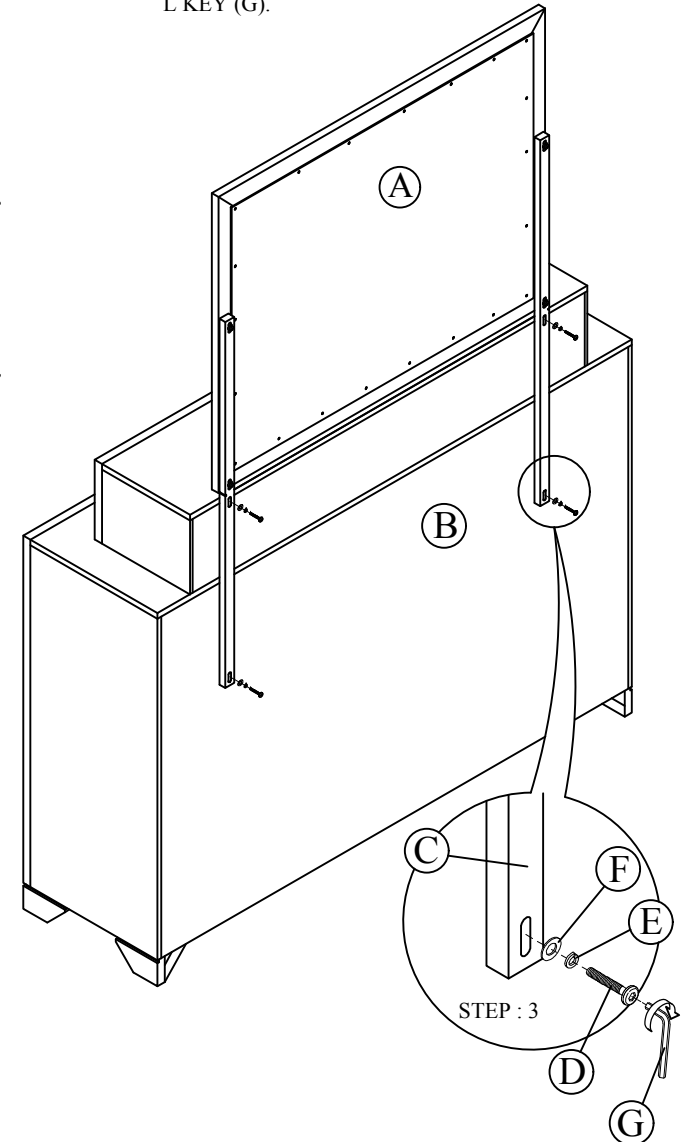

**NOTE : MUST TIGHTEN SCREWS PERIODCALLY WITH USE SCREW WILL BECOME LOOSE.
 CHECK TIGHTNESS OF ALL SCREW EVERY 6-8 WEEKS.**







INSTRUCTIONS D'ASSEMBLAGE

DESCRIPTION : COMMODE / MIROIR

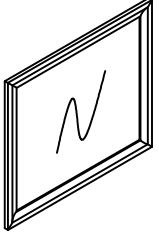
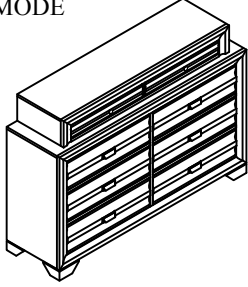
MODEL :

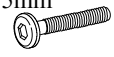
C5236A-040-8DXX / C5236A-050-MHXX
 C5236W-040-8DXX / C5236W-050-MHXX
 C5236W-047-8DXX / C5236W-050-MHXX
 C5236G-040 / C5236G-050

REVISION : B

N°	PIECES & QUINCAILLERIE	Q'té
A	MIROIR 	1PCE
B	COMMUNE 	1PCE
C	RENFORT DU MIROIR 	2PCES
D	VIS JCBC M6 X 35mm 	8PCES
E	RONDELLE A RESSORT 1/4" mm 	8PCES
F	RONDELLE PLATE 1/4" x 20mm 	8PCES
G	CLE L M4 	1PCE

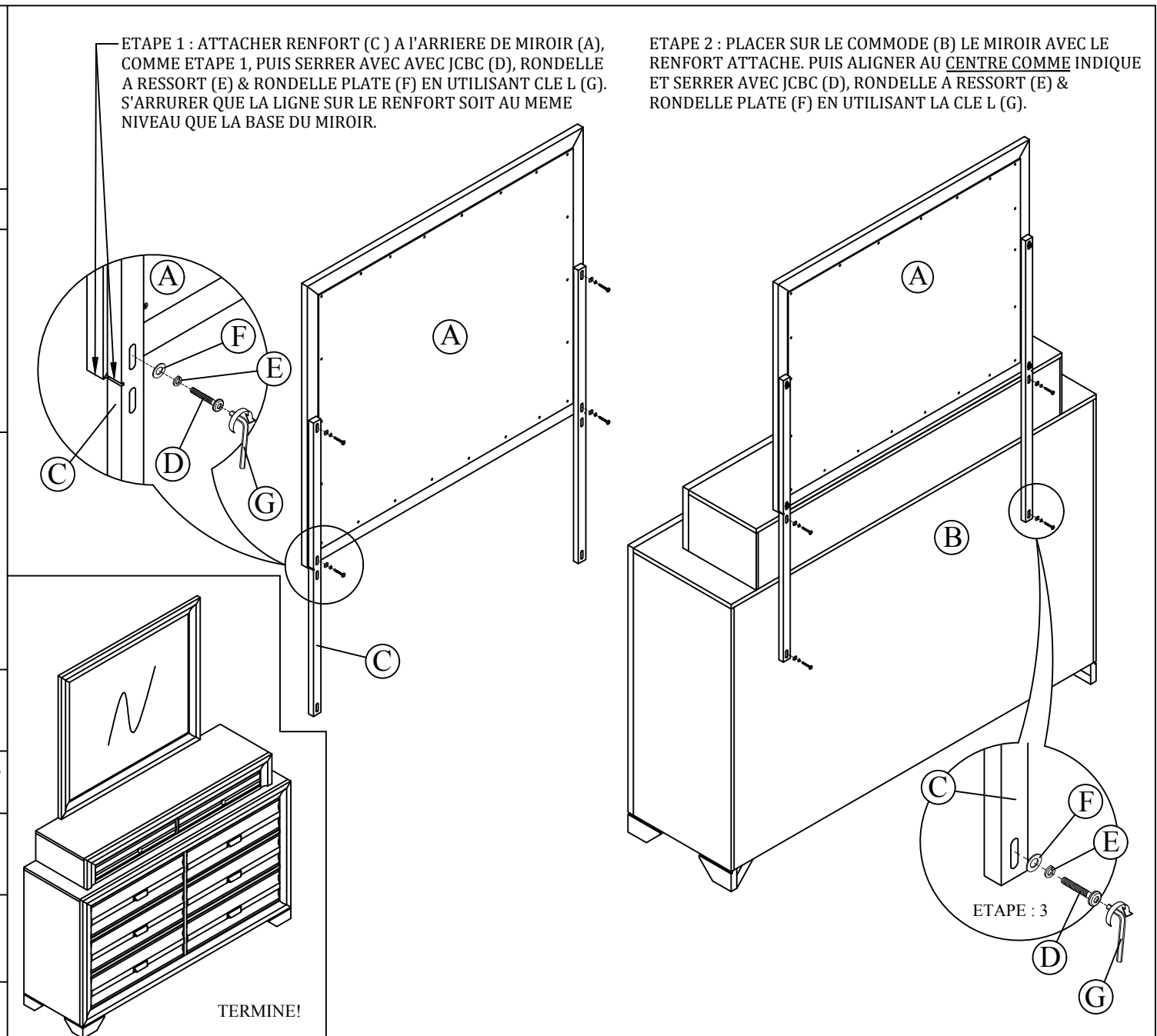

REMARQUE: RESERRER LES VIS(/BOULONS) RÉGULIÈREMENT. À L'USAGE, LES VIS SE DÉSERRENT.
 VÉRIFIER QUE LES VIS SOIENT SERRÉES TOUTES LES 6-8 SEMAINES.